

T-Seam® Standing Seam Roofing System Standard Details



Tiger Profiles and Insulation L. L. C.





T-Seam Standing Seam was used for the roofing at Za'abeel Hall of the Dubai World Trade Centre.



Cover: T-Seam used for roofing the Ticketing Office at the Nad Al-Sheba Race Course, Dubai. T-Seam is ideal in situations where lightweight

yet durable roofing is required, and easily conforms to the demanding specifications of modern architectural design.

Tiger Profiles & Insulation L.L.C.

Tiger Profiles and Insulation was established in 1994 as a fully owned subsidiary of Tiger Steel Engineering to provide specialized service in the metal building construction industry. In the last decade the company has grown to be recognized as a market leader in the design and supply of the cold formed and insulated metal building components for roofs, walls, false ceiling and floor decks.

Tiger Profiles & Insulation employs a team of highly skilled and experienced professionals, who work together with the customers to provide a complete system solution. This entrepreneurial spirit of the employees has enabled the Company to successfully launch new products and develop new markets.

The Company is committed to maintain the highest level of Quality Control procedures as well as the health and safety policies resulting in high quality products and ensuring complete customer satisfaction. The company has the accreditation of ISO 9002 since 2000.

On the following pages, we have illustrated some typical T-Seam® roof construction details. These details are only suggestions and must be verified for each project in terms of correctness and suitability.

T-Seam® Standing Seam Roofing System Standard Details

T-Seam® Standard Details

DRAWING NO.

SK 01

Drawing No.	Drawing Title	Page
SK 01	Typical Duo-pitch Detail	01
SK 02	Mono Pitch Ridge Detail	02
SK 03	Typical Roof Construction Detail	03
SK 04	Typical Roof Construction Detail	04
SK 05	Typical Rafter Construction Detail	05
SK 06	Gable with Wall Cladding	06
SK 07	Gable Detail with Parapet	07
SK 08	Peak Detail with Fascia	08
SK 09	Peak Detail on Block Wall	09
SK 10	Eave Gutter Details with Fascia	10
SK 11	Gutter Details without Fascia	11
SK 12	Valley Gutter Details	12
SK 13	Lateral Expansion Joint Detail	13
SK 14	Stepped Lateral Joint Detail	14
SK 15	Typical Overlap Pattern	15
SK 16	Typical Overlap Detail	16
SK 17	Expansion Joint Detail	17
SK 18	Roof Skylight Opening Detail	18
SK 19	Roof Skylight Opening Detail	19
SK 20	Soaker Panel Detail	20
SK 21	Fixing Clip Detail	21
SK 22	T-Seam® Accessories	22

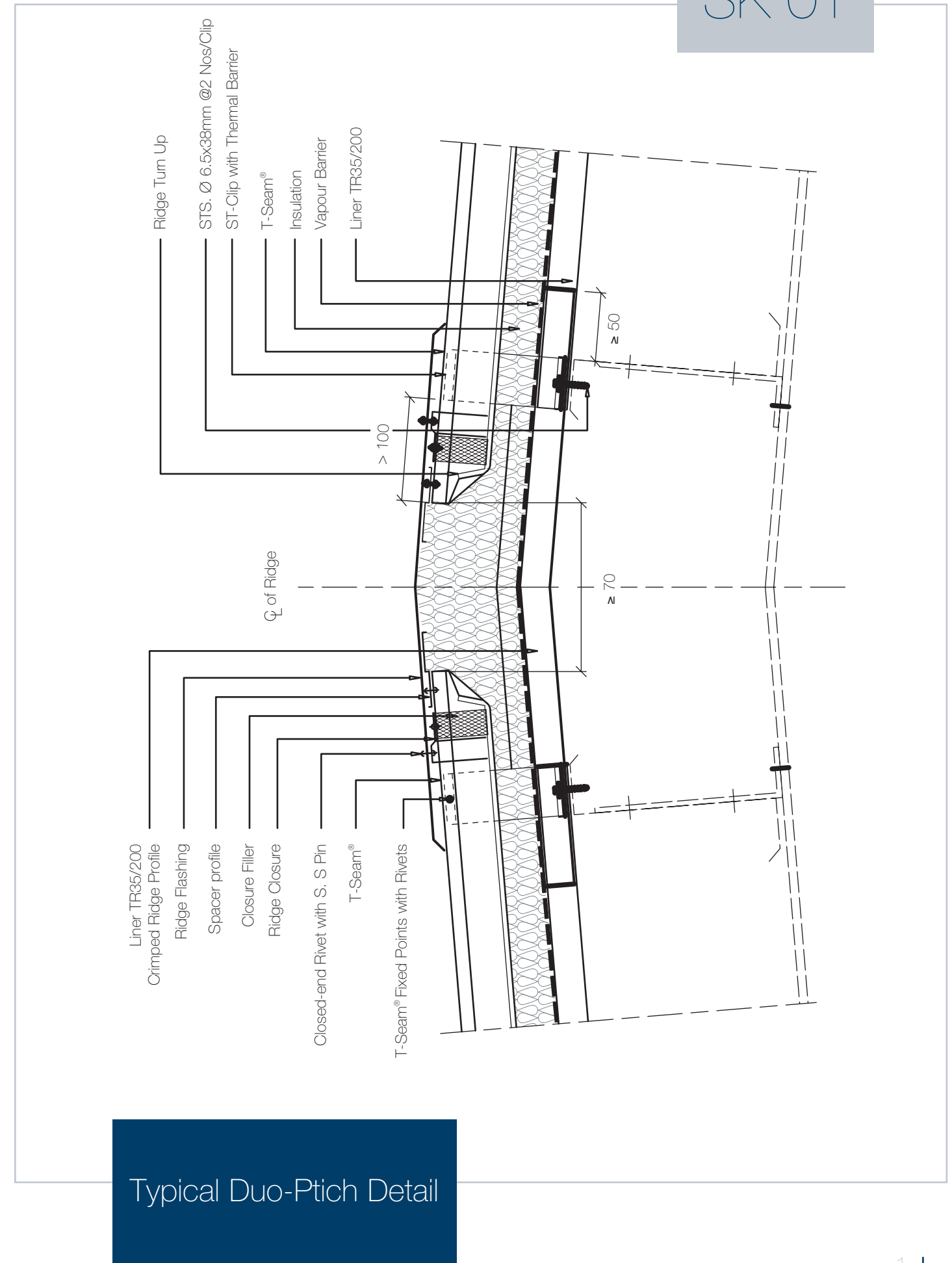

Typical Duo-Pitch Detail

T-Seam® Standard Details

- Peak Flashing
- Spacer Profile
- Ridge Turn Up
- T-Seam® Fixed Point (ref. Detail)
- Closure Filler
- Ridge Closure
- Closed-end Rivet
- Loose Insulation
- Inner Support Flashing
- Spacer Support

- T-Seam®
- Insulation
- Vapour Barrier
- Liner

- Steel Structure
- Wall Panel

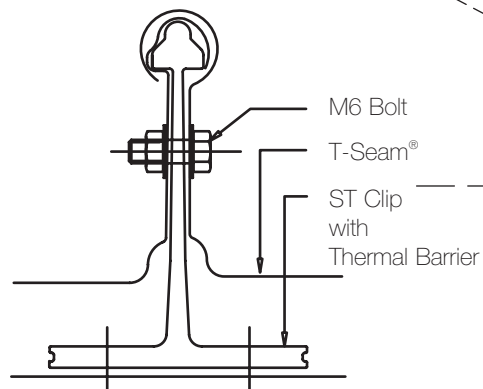

T-Seam® Fixed Point

Mono Pitch Ridge Detail & T-Seam® Fixed Point Detail

T-Seam® Standard Details

- T-Seam® Roof Panels
- ST Clip with Thermal Barrier
- Insulation
- Vapour Barrier
- Liner Sheet

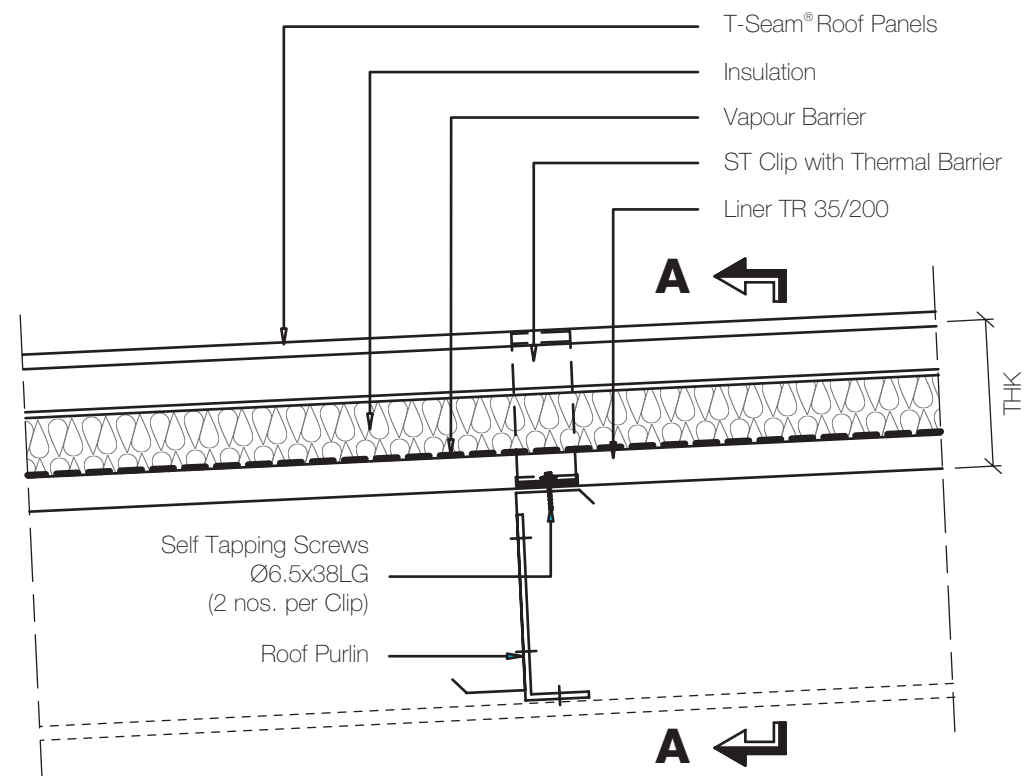
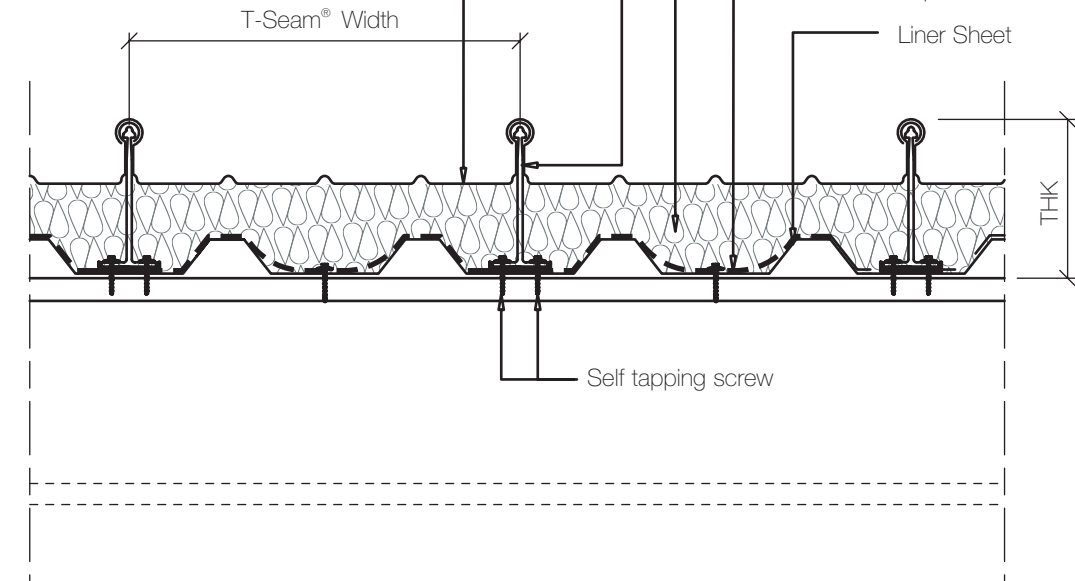

Section A -A

Typical Purlin Roof Construction Detail Without Hat Spacer

T-Seam® Standard Details

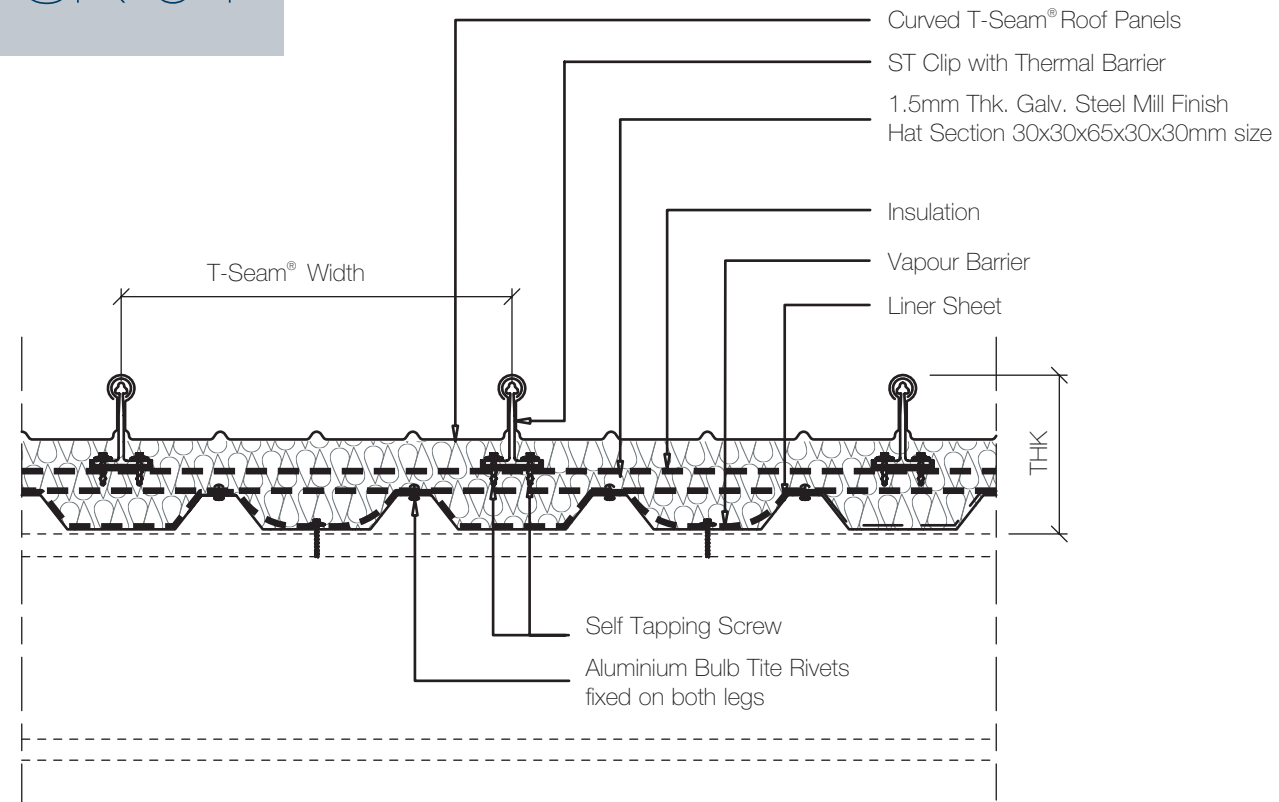

Section A -A

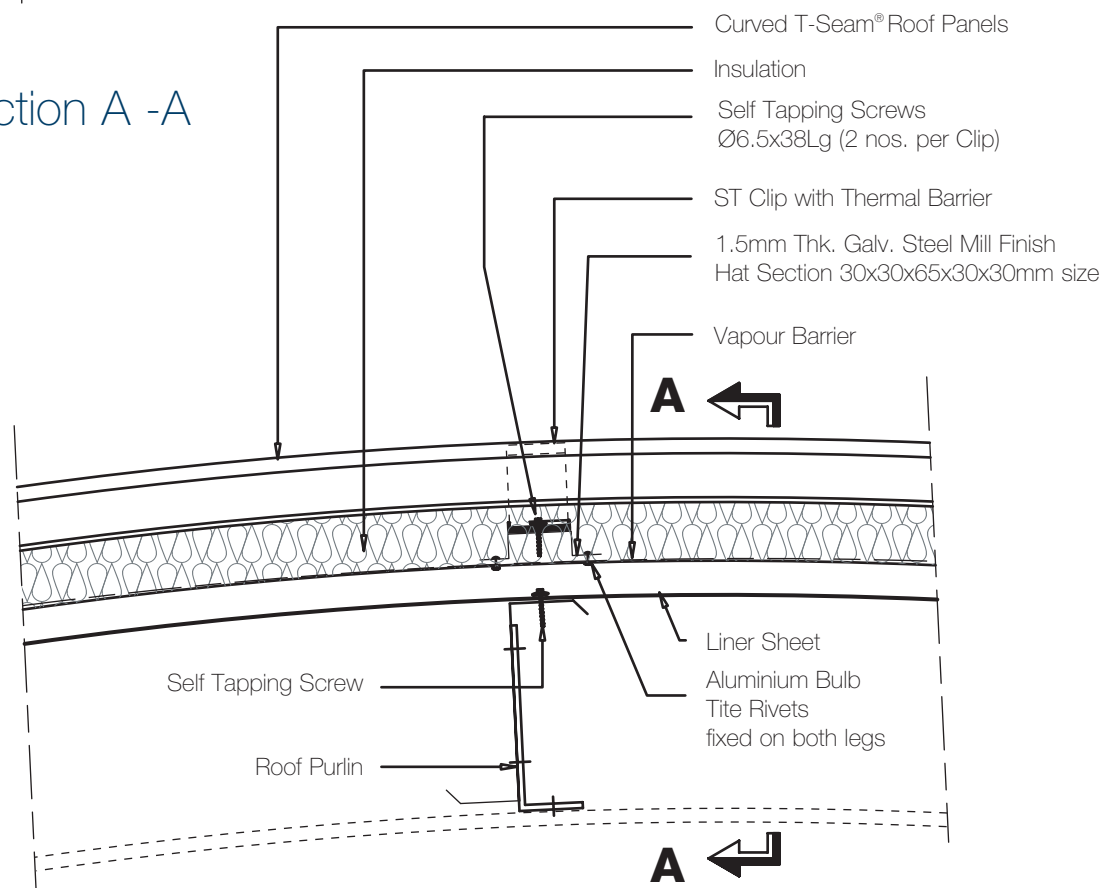

Typical Purlin Roof Construction Detail With Hat Spacer

T-Seam® Standard Details

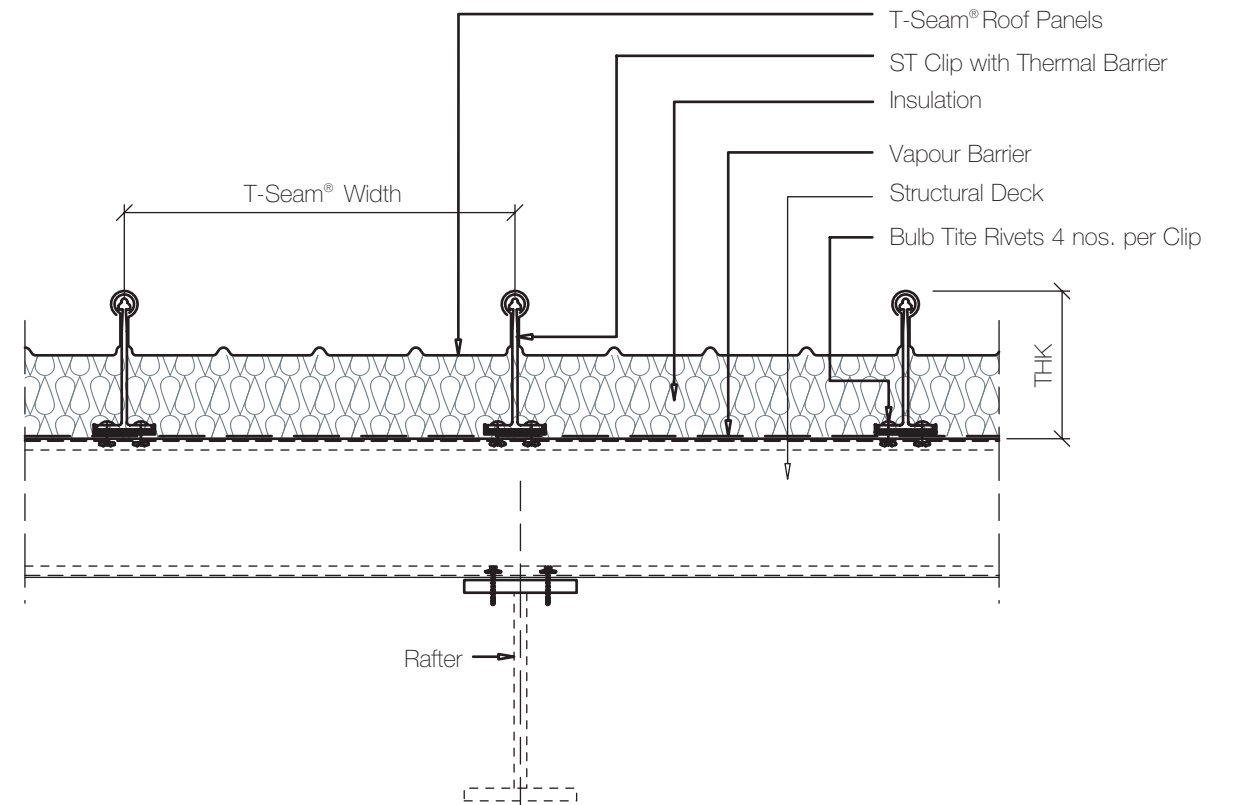

Section A -A

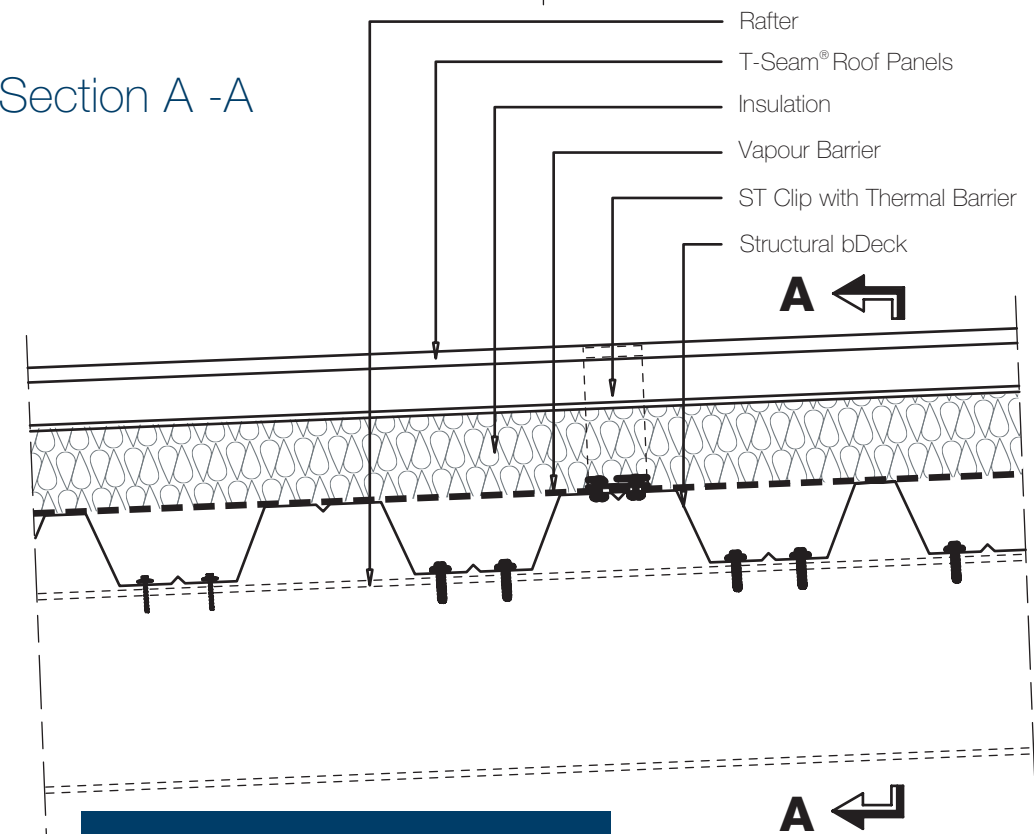

Typical Rafter Roof Construction Detail

T-Seam® Standard Details

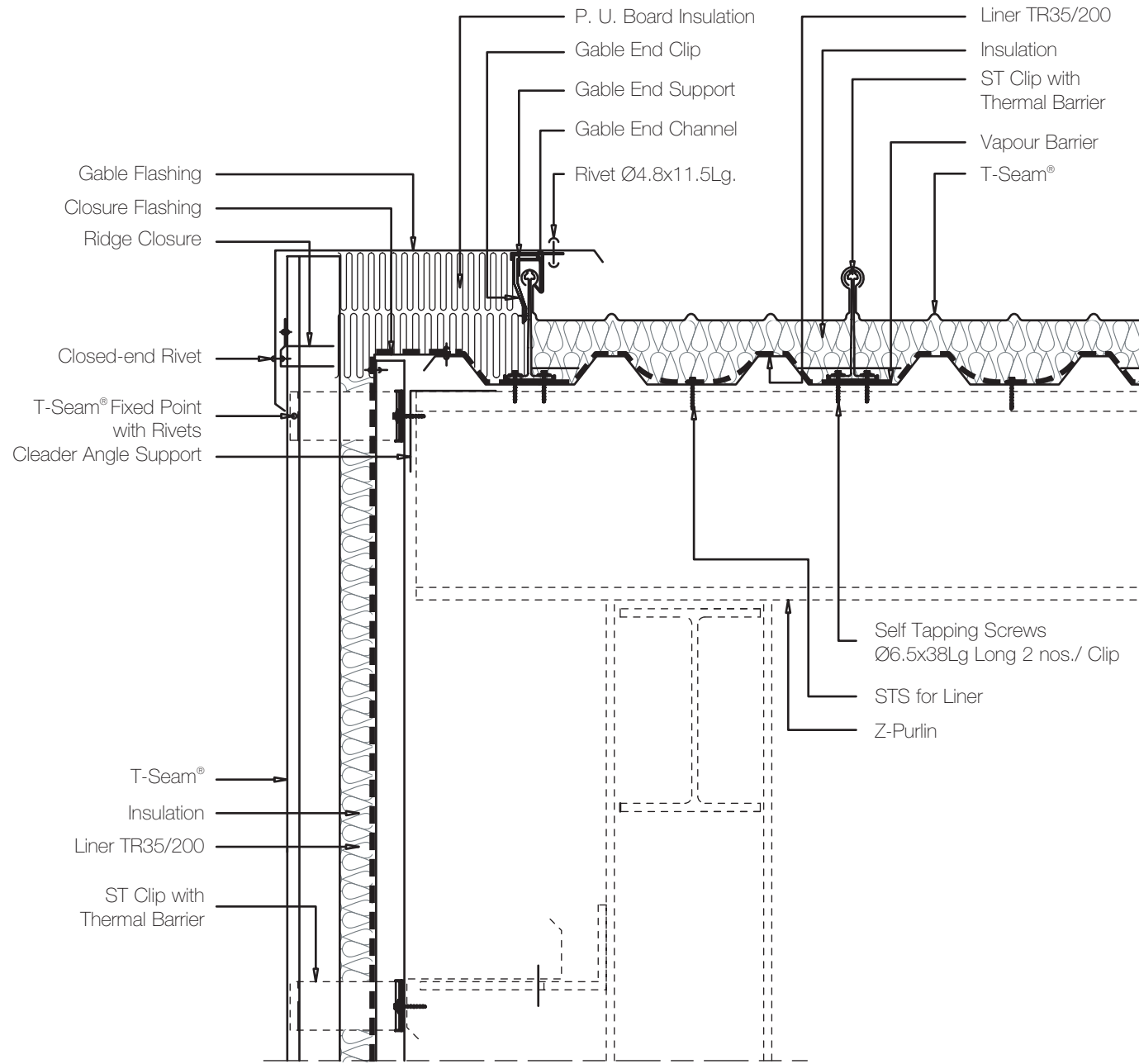

Gable with Wall Cladding

T-Seam® Standard Details

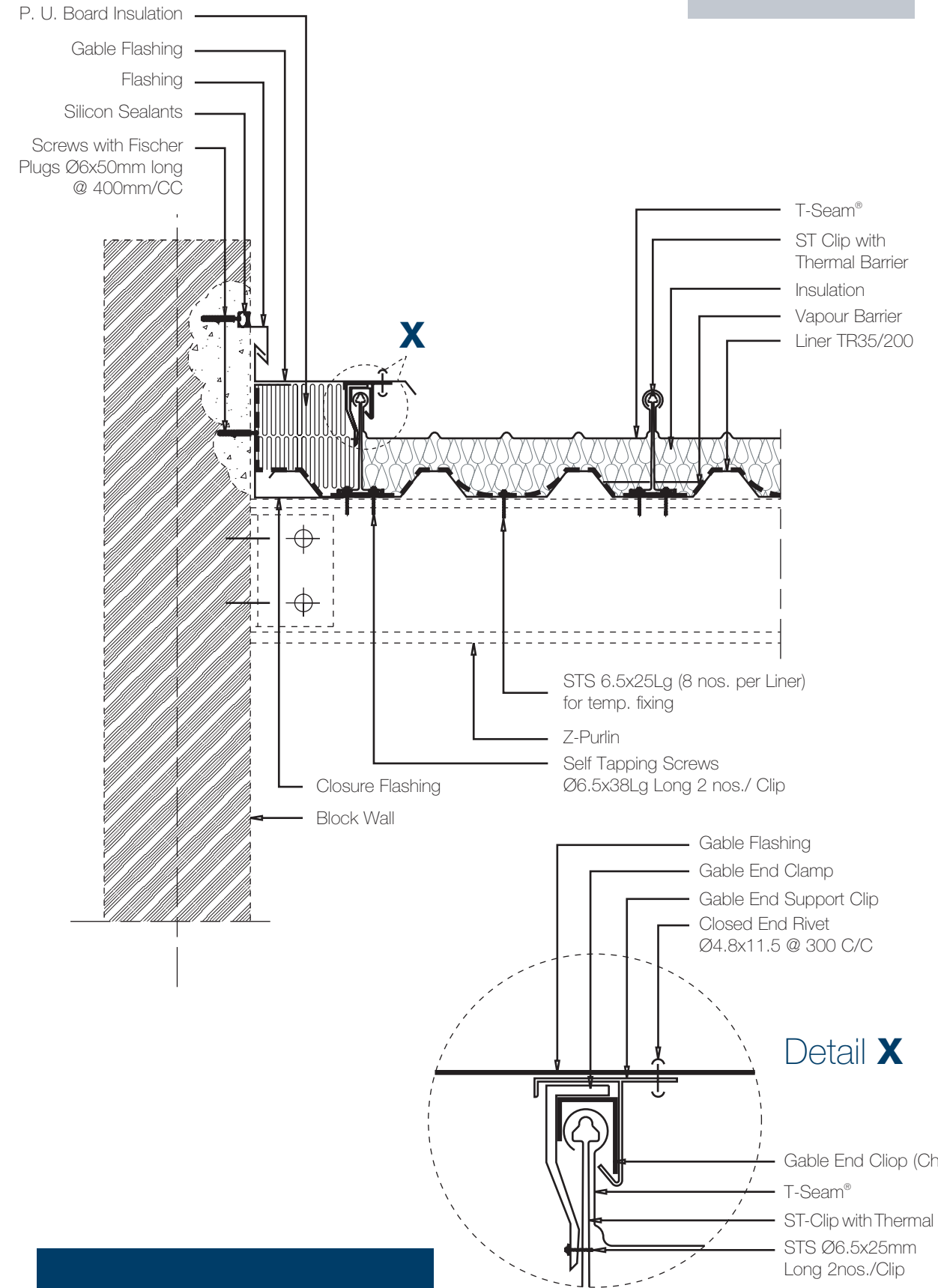

Gable Detail with Parapet

T-Seam® Standard Details

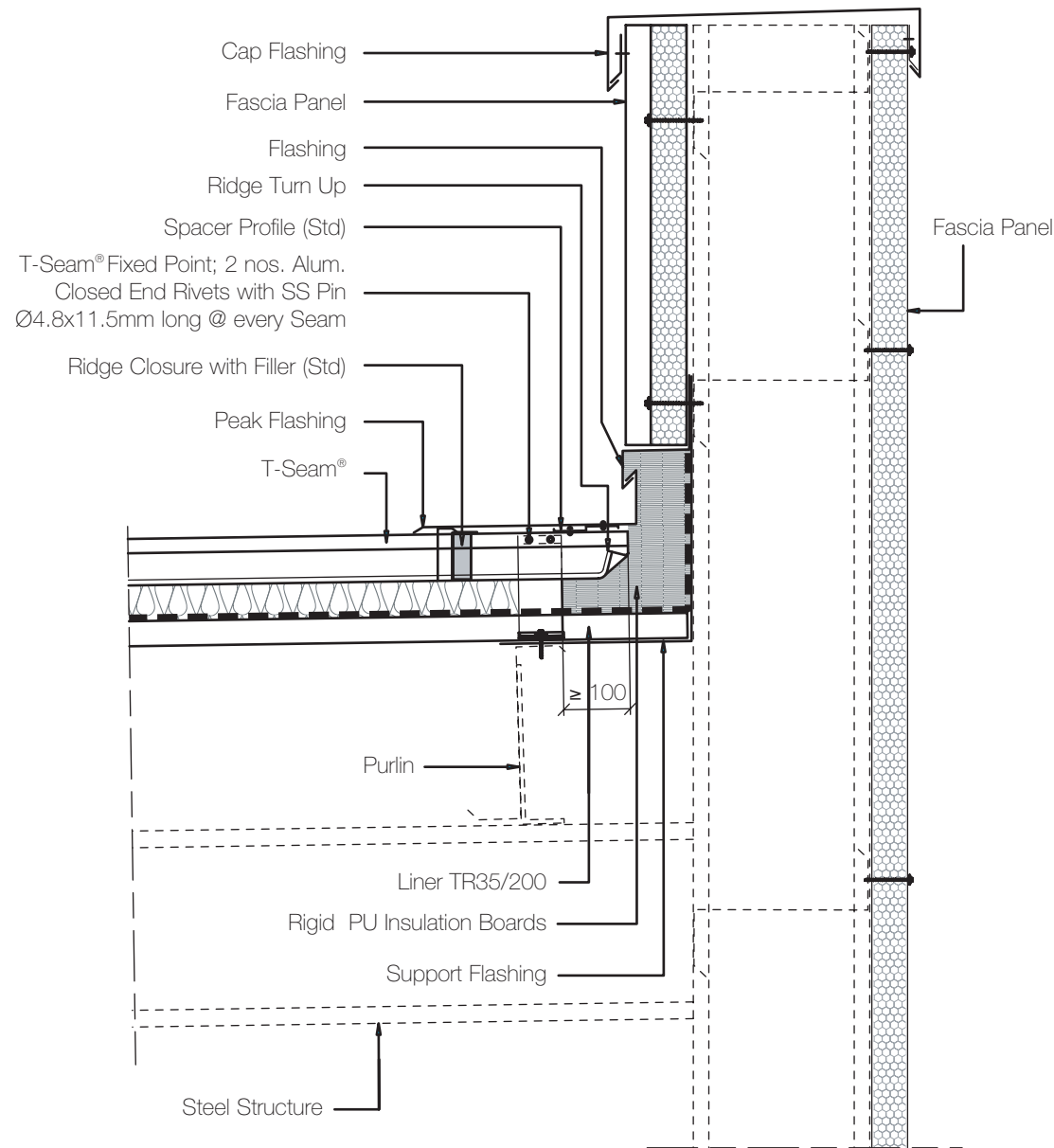

Peak Detail with Fascia

T-Seam® Standard Details

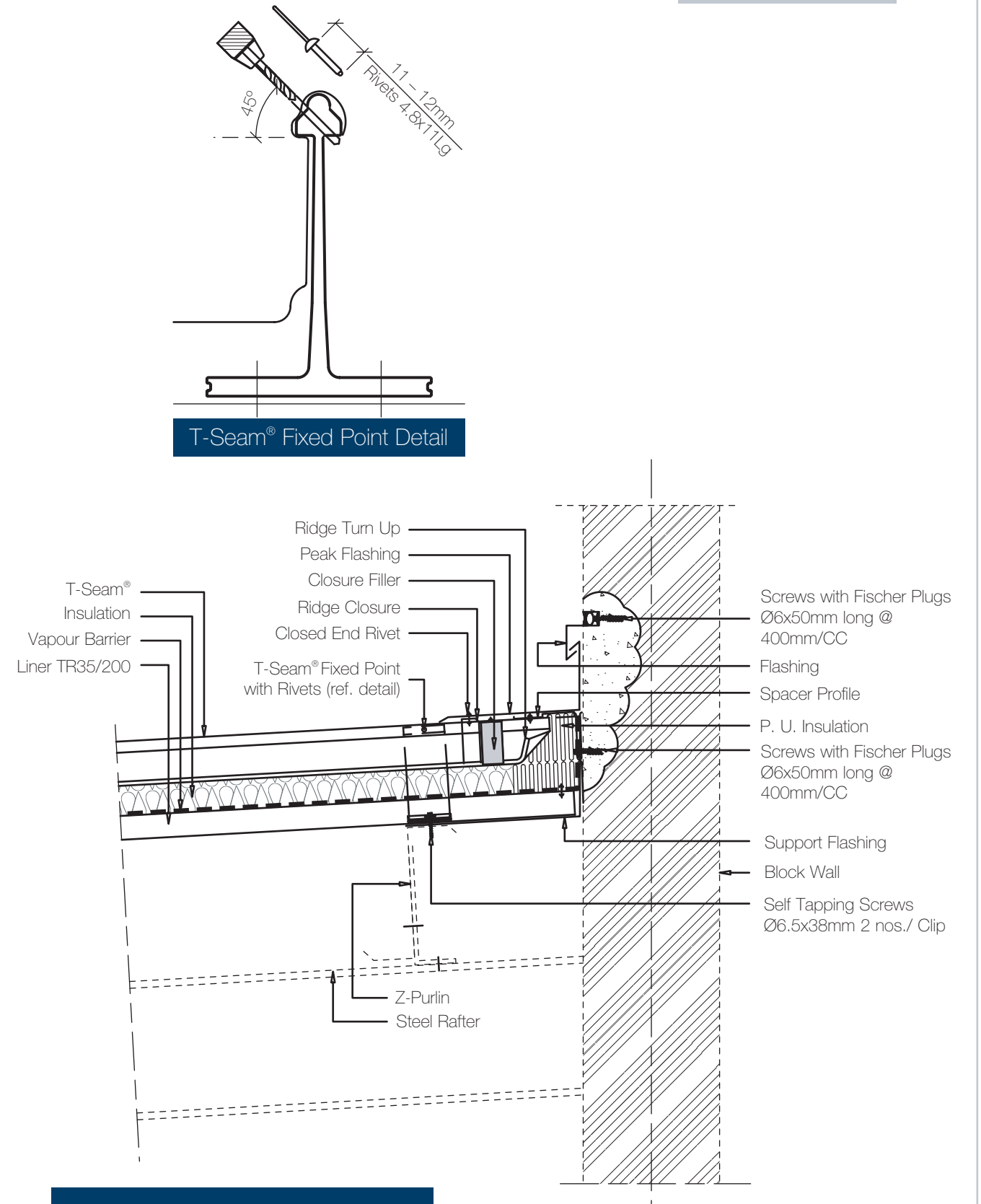

Peak Detail on Block Wall

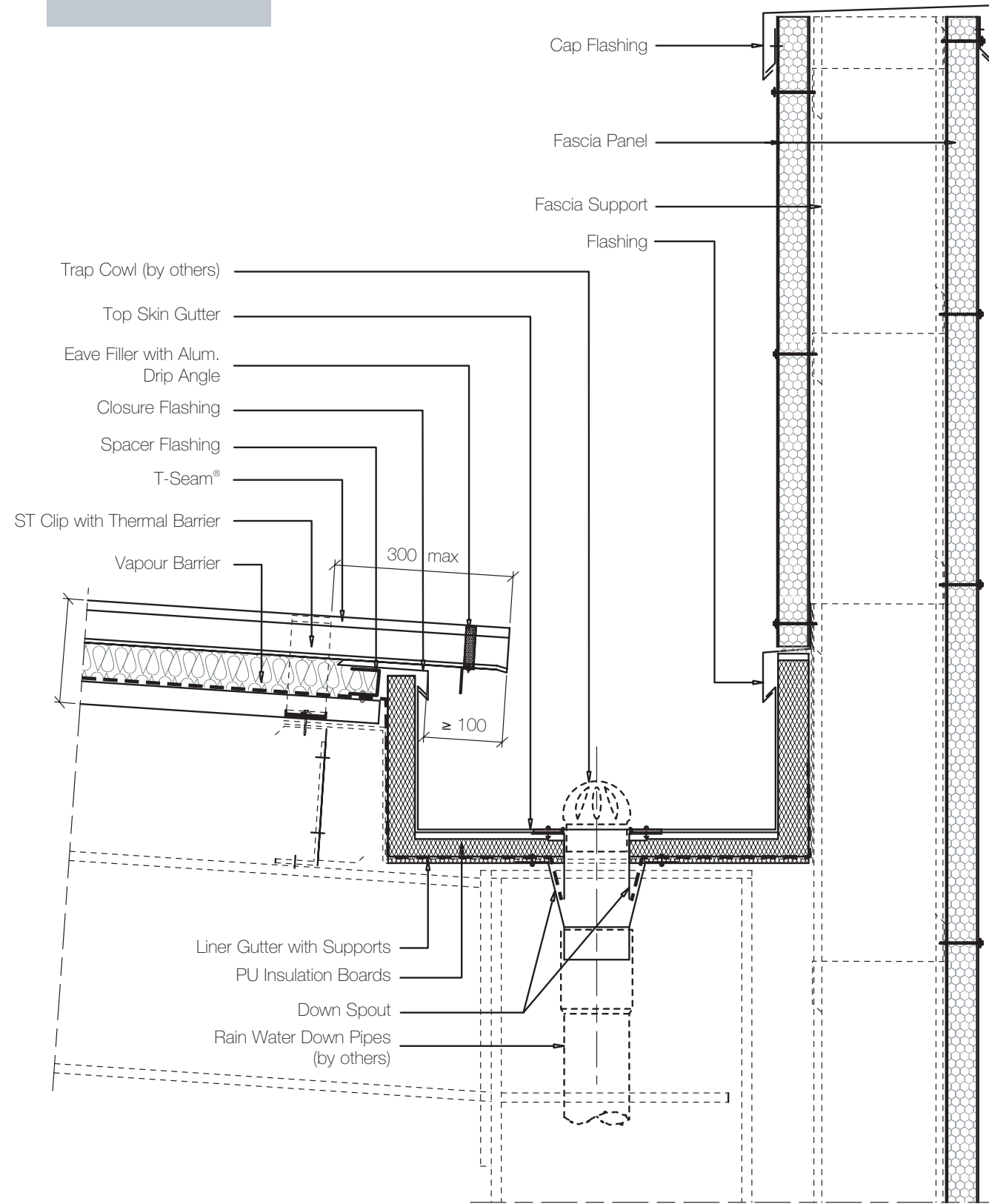

Eave Gutter Details with Fascia

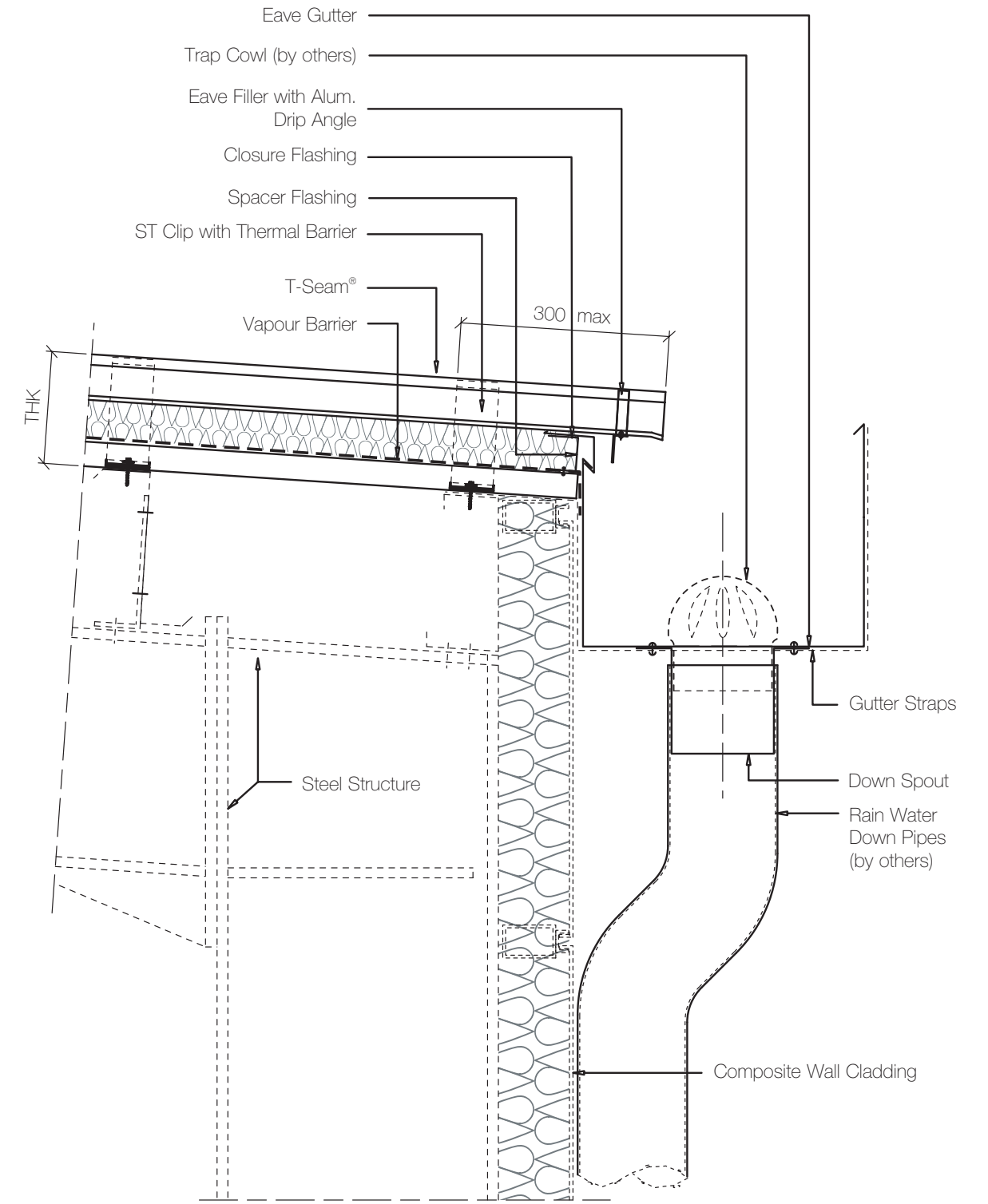

Gutter Details without Fascia

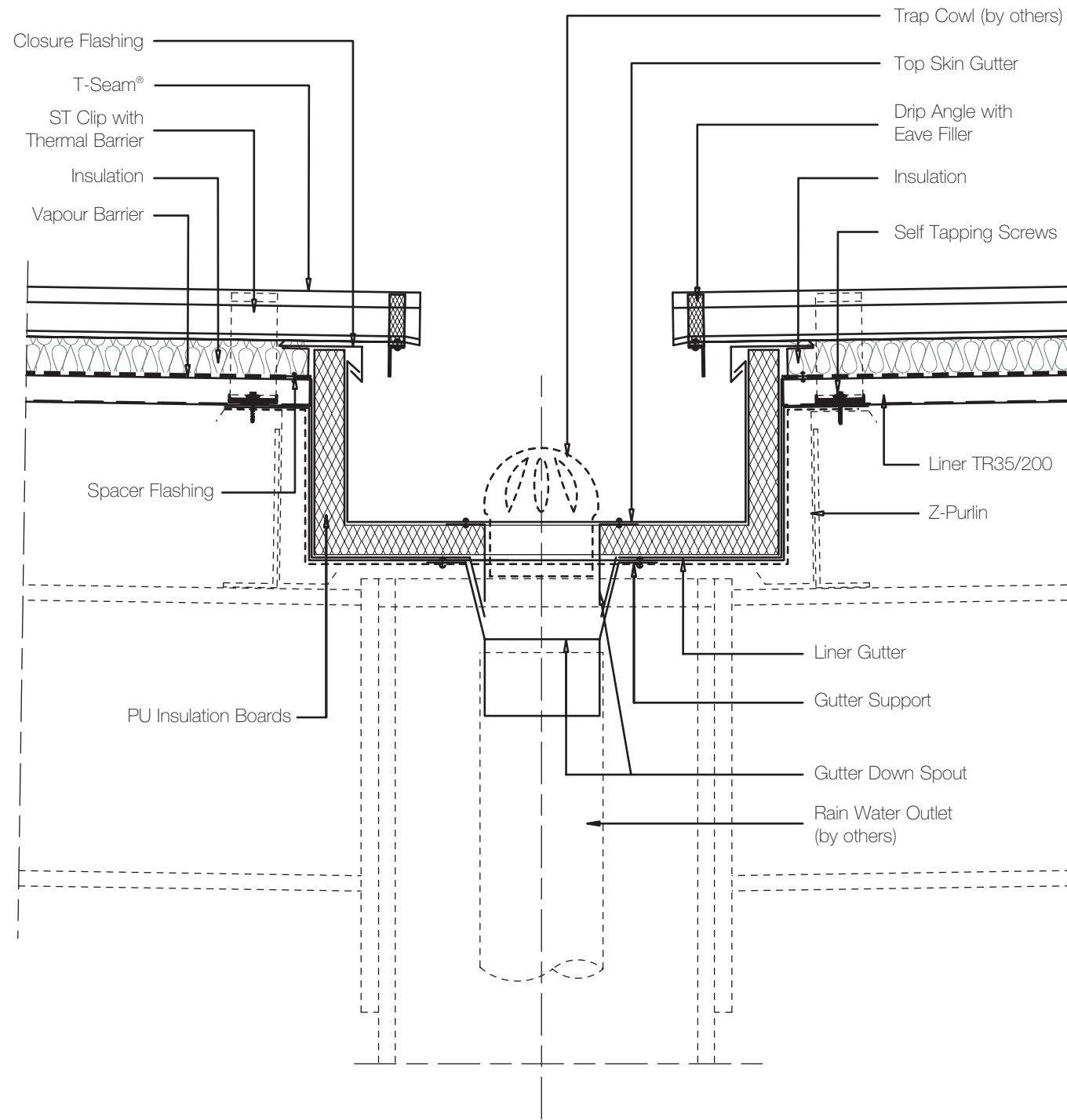

Valley Gutter Details

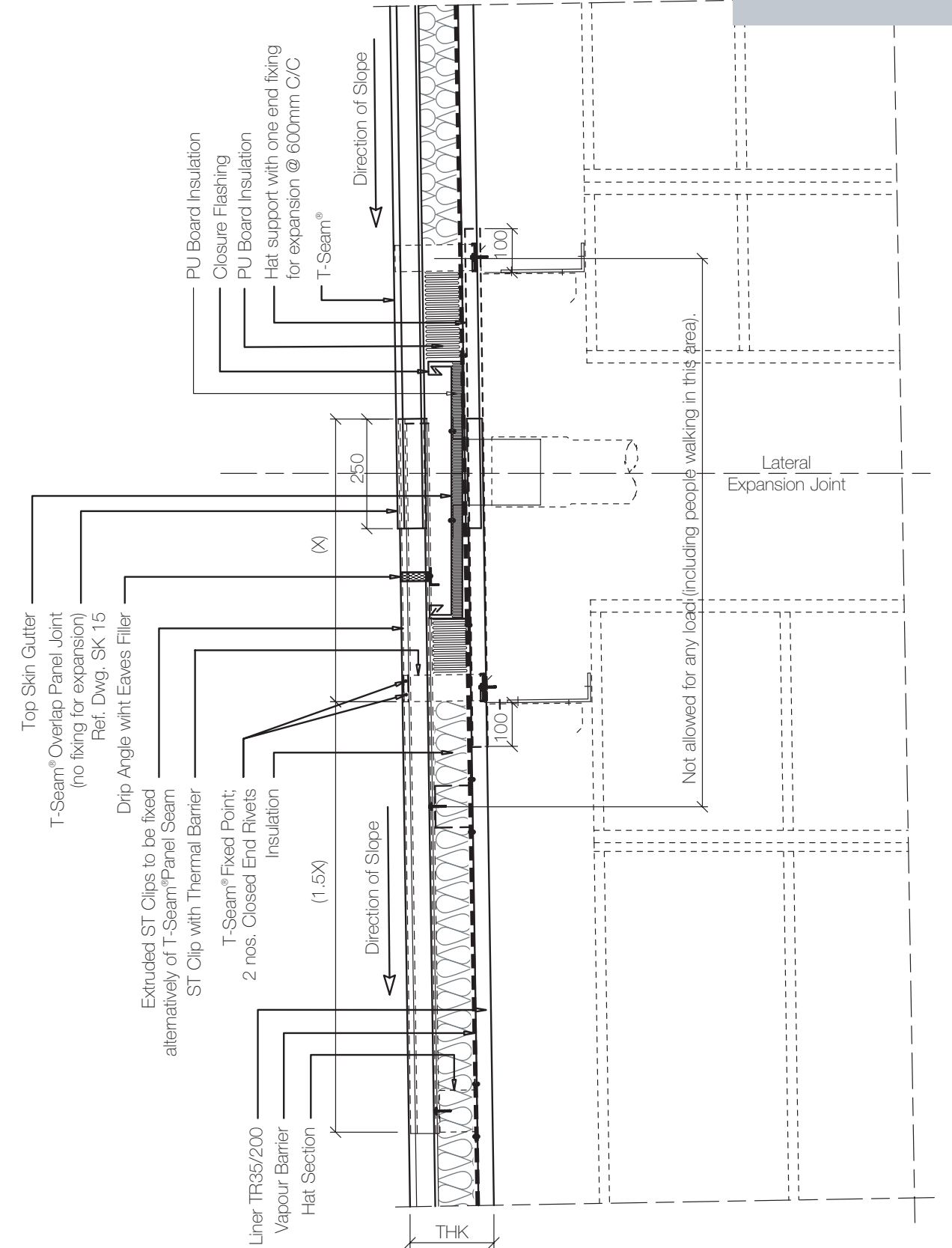

Lateral Expansion Joint Detail

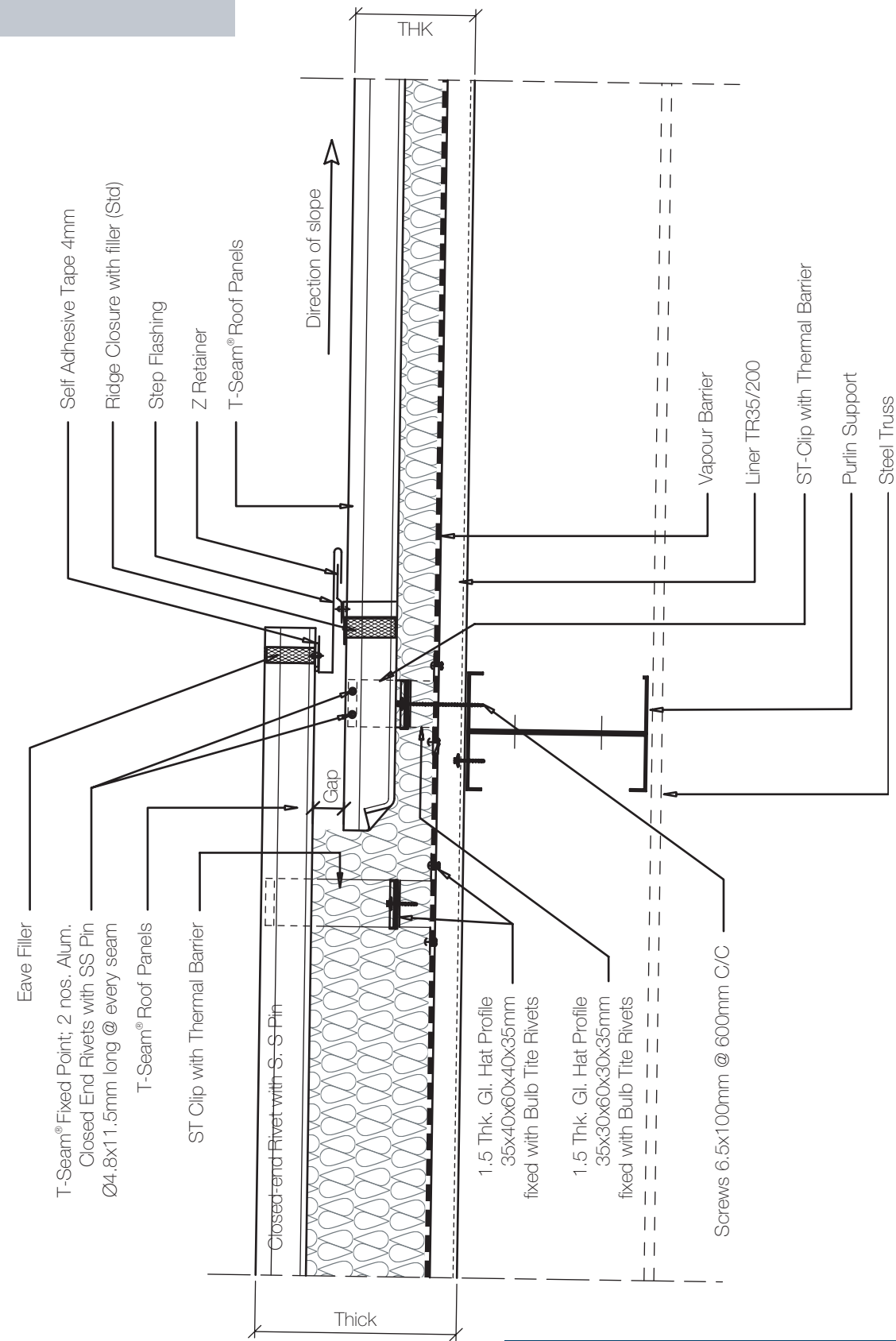

Stepped Lateral Joint Detail

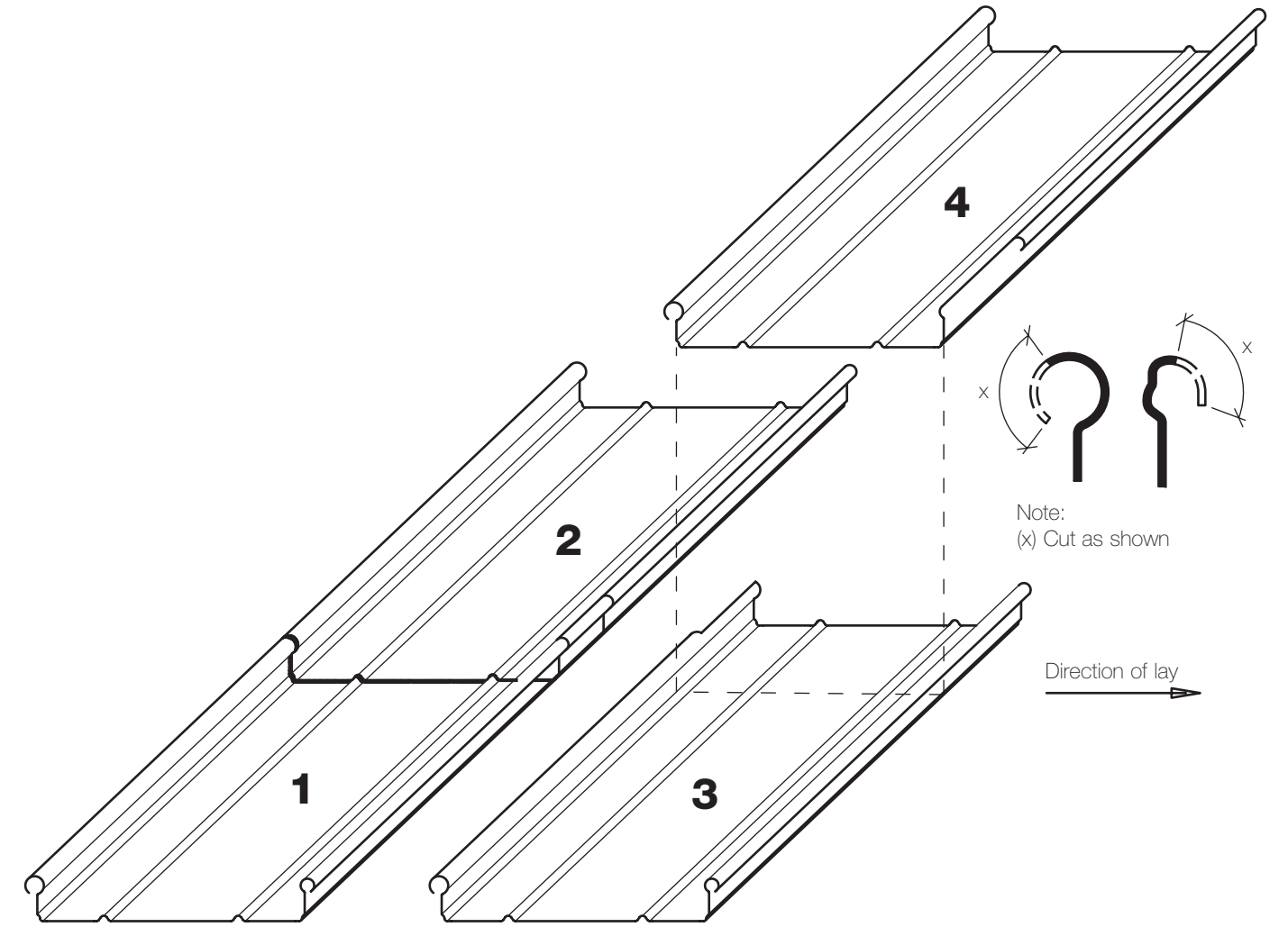

Sequence of Transverse Joint

Note:
1, 2, 3, & 4 indicates the
sequence of laying of sheets

Typical Overlap Pattern

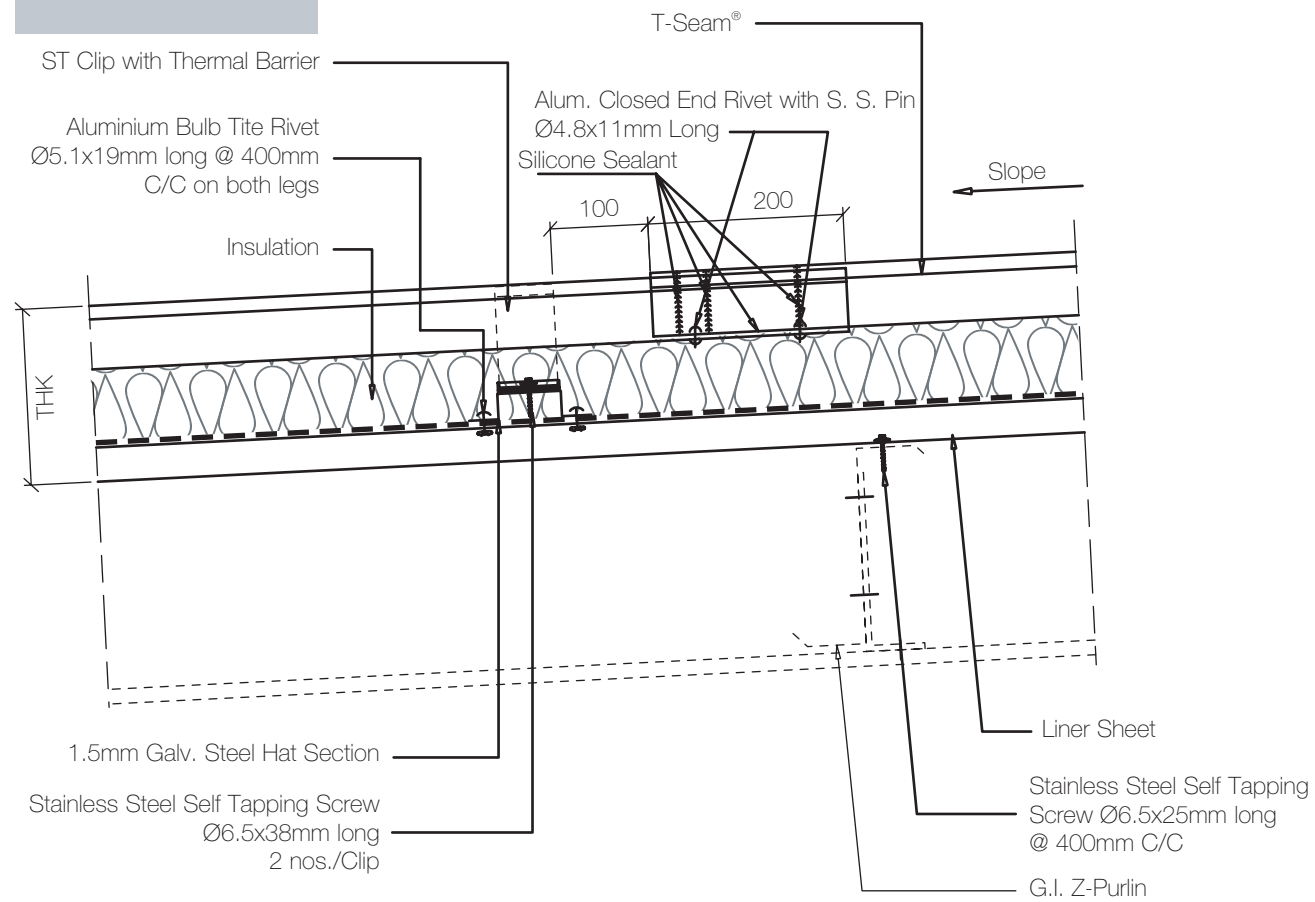

Plan View

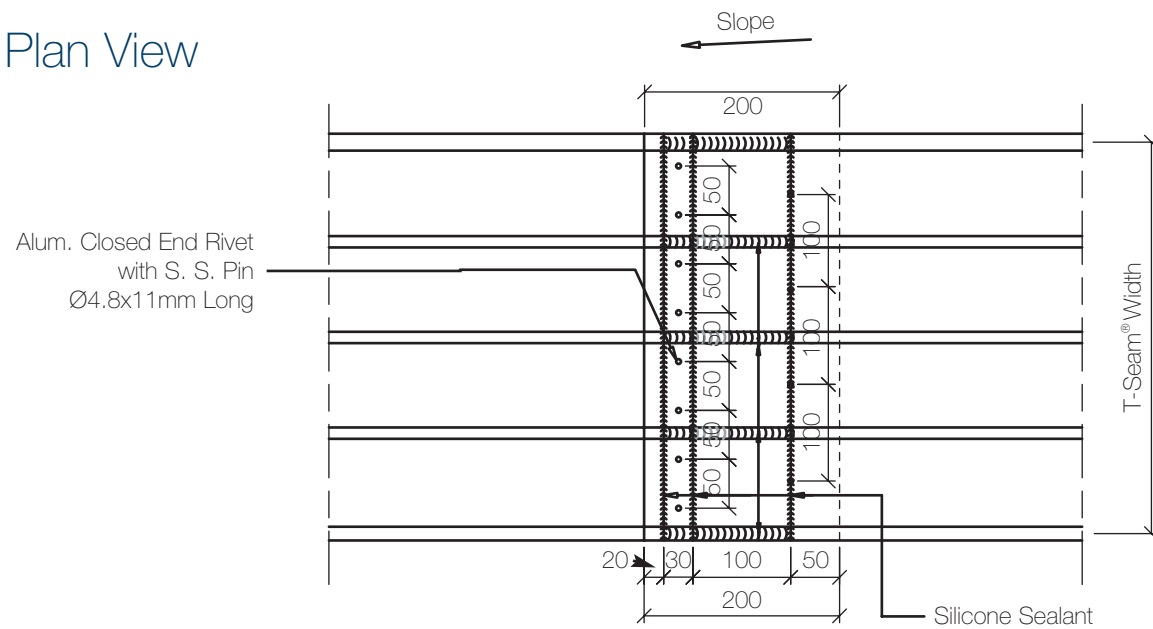

Typical Overlap Detail

Detail - X

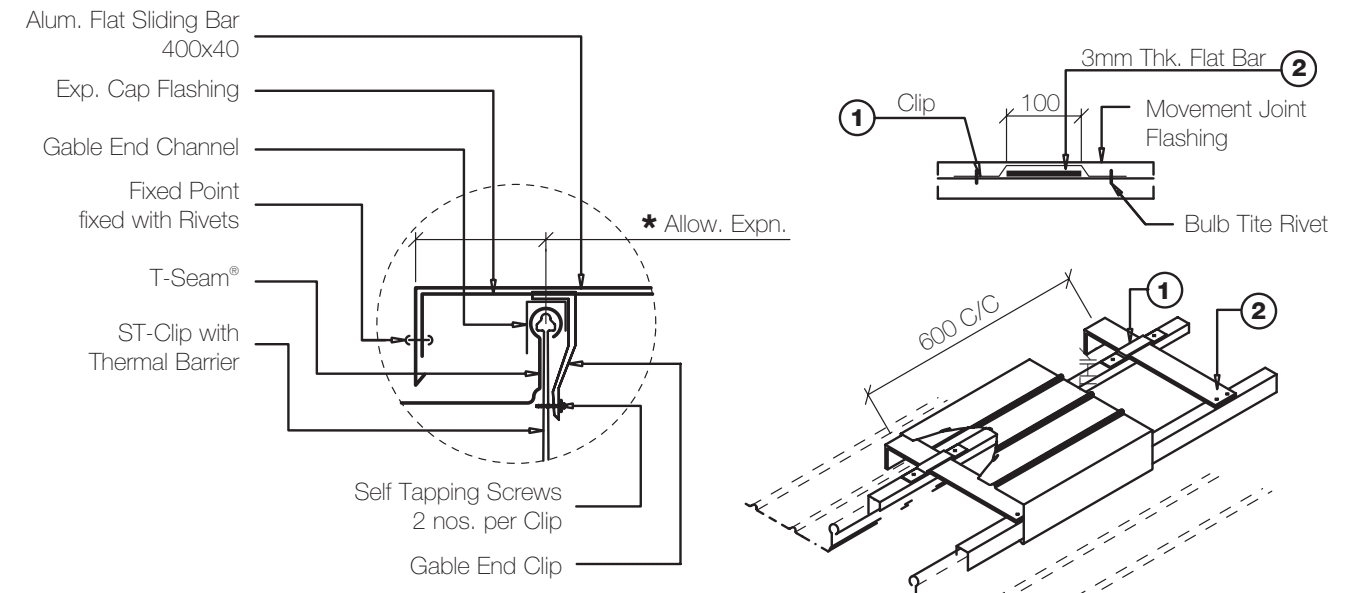

Isometric View of Sliding Bar Arrangement

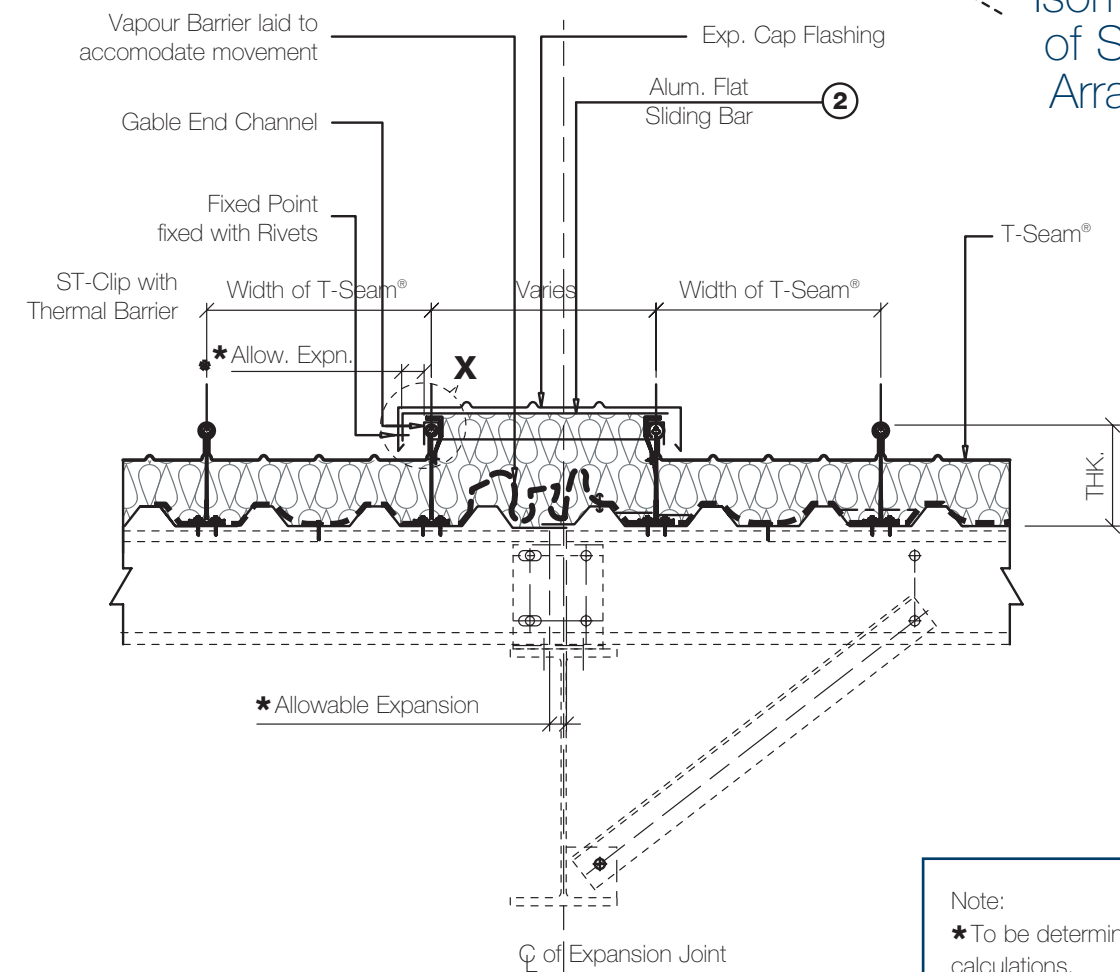

Note:
* To be determined by calculations.

Expansion Joint Detail

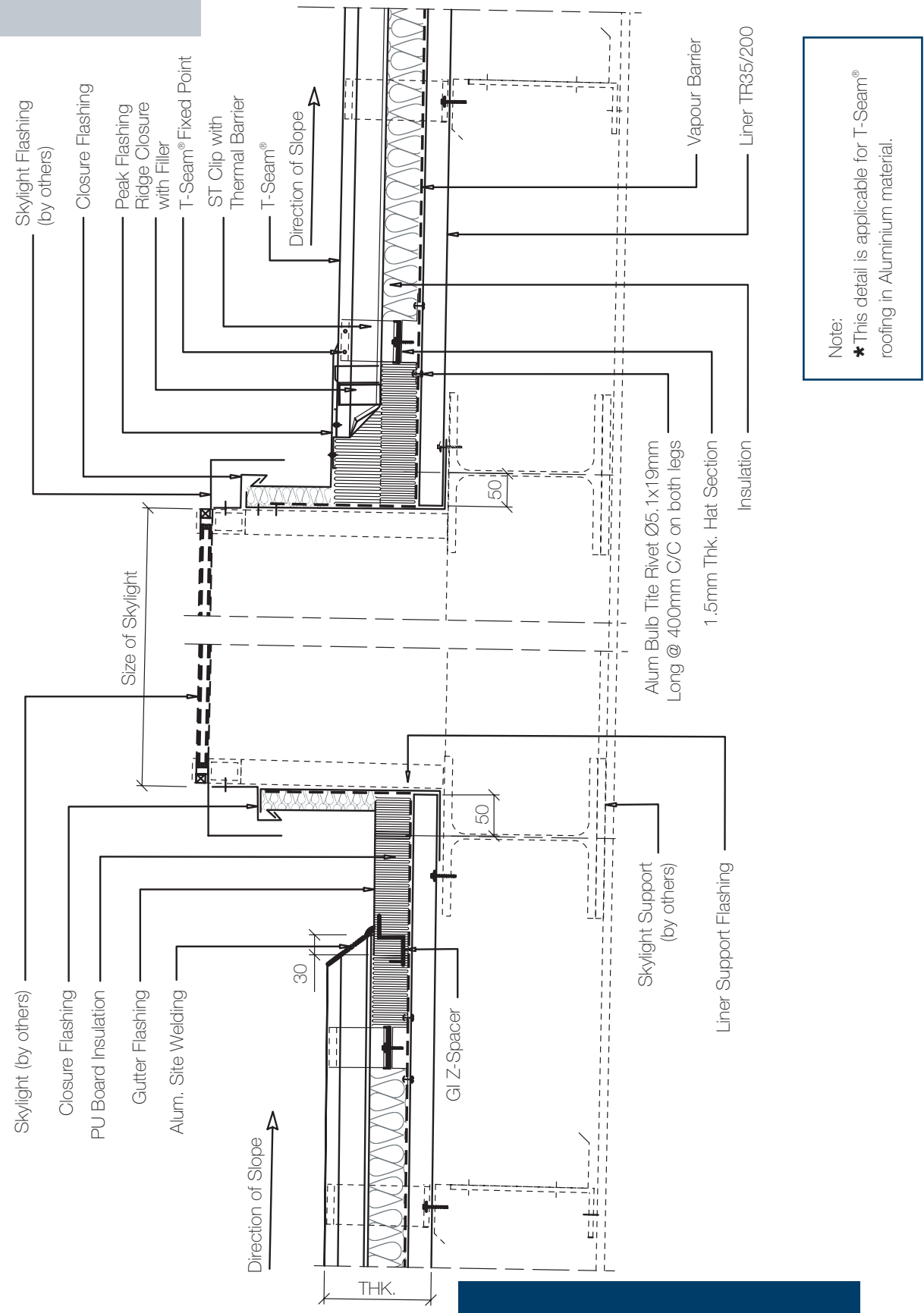

Roof Skylight Opening Detail
(Along the Roof)

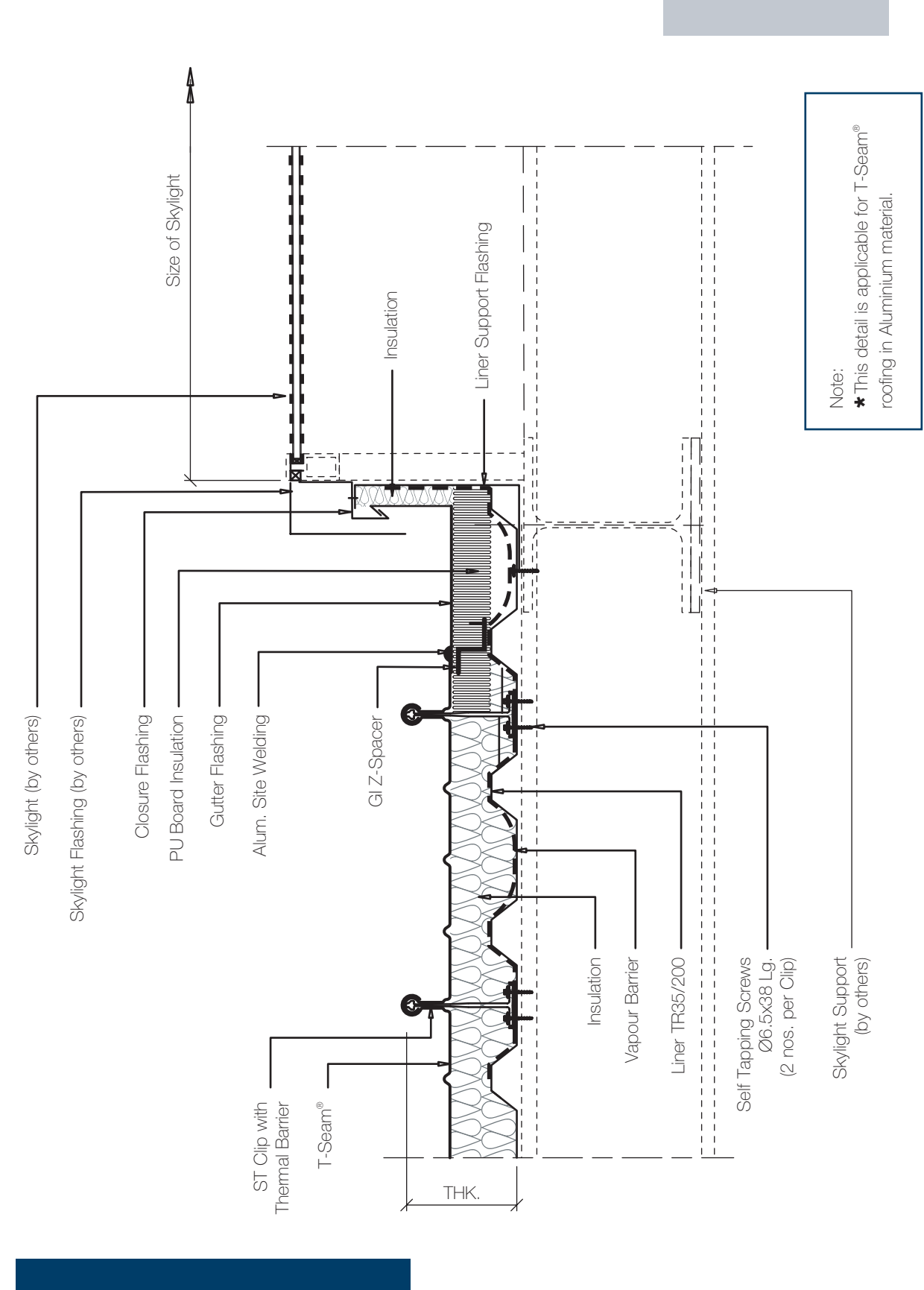

Roof Skylight Opening Detail
(Across the Roof)

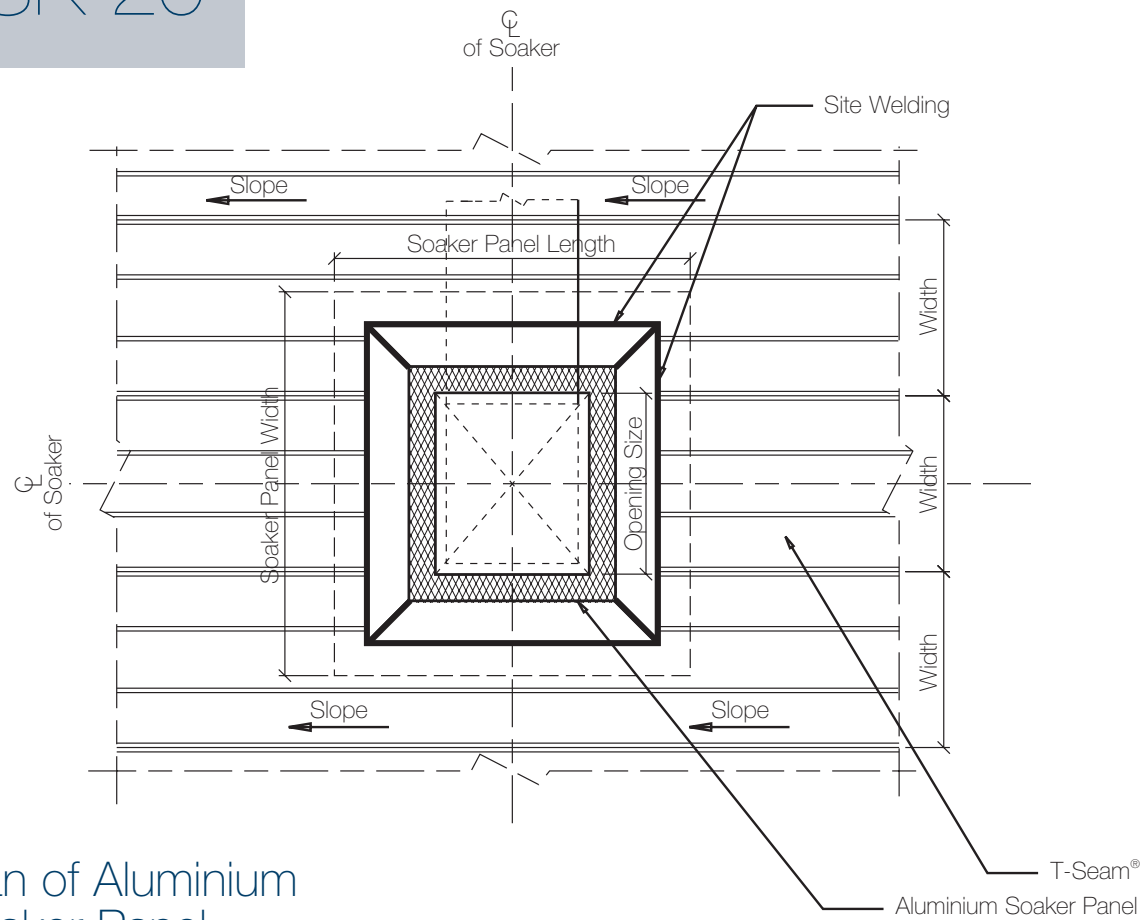

Plan of Aluminium Soaker Panel

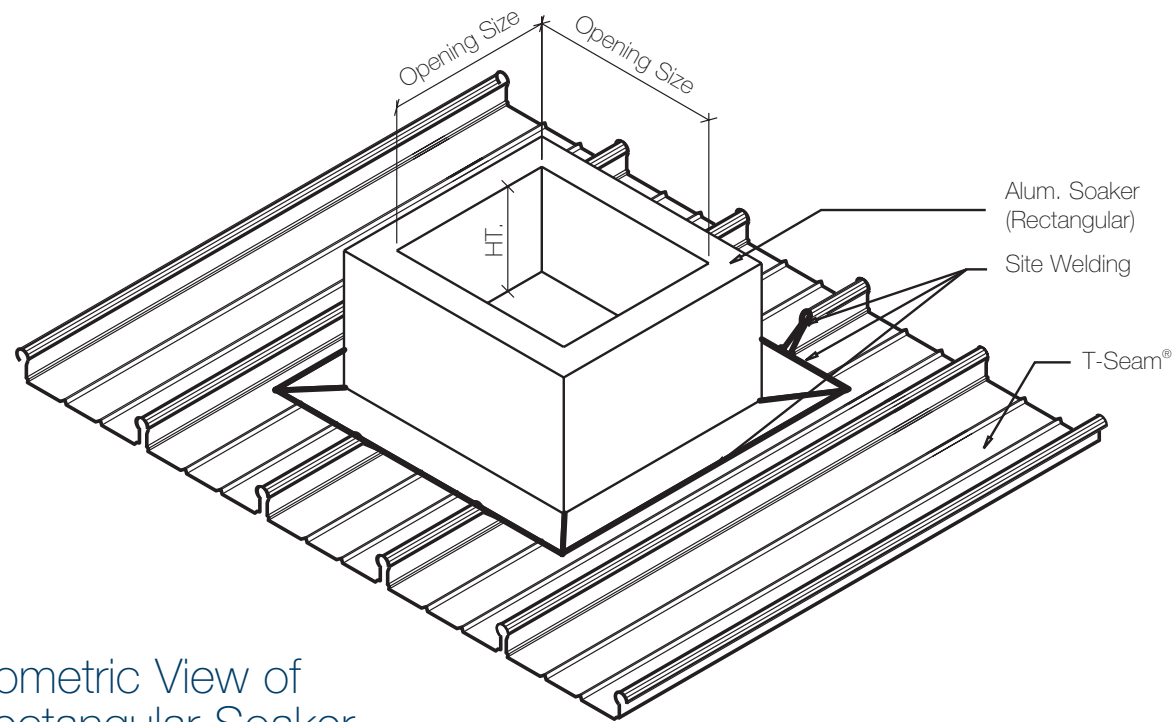

Isometric View of Rectangular Soaker

Soaker Panel Detail

T-Seam® Fixing Clips

Type T-25

Type T-50 to T-135

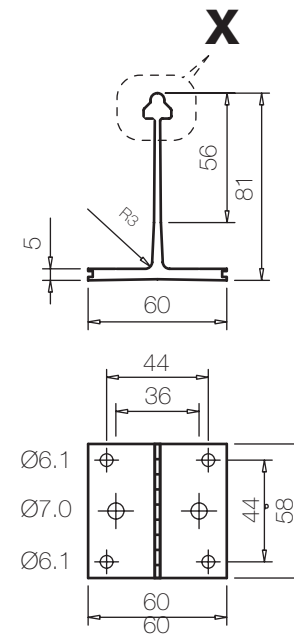

Detail - Z

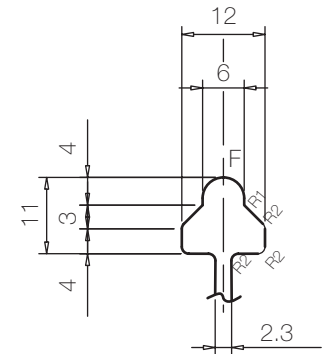
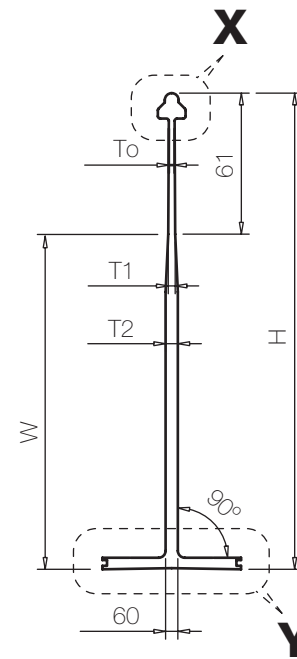

Detail - X

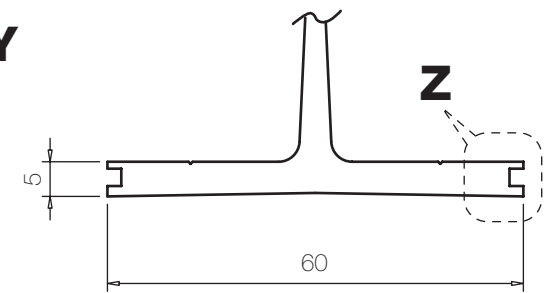

Detail - Y

T-Seam® Clip Type T-25 to T-135 (mm)

Type	T-25	T-50	T-75	T-95	T-105	T-115	T-125	T-135
H	81	106	131	151	161	171	181	191
W	25	45	70	90	100	110	120	130
To	2.5	2.5	2.5	2.5	2.5	2.5	2.5	2.5
T1	3.0	3.0	3.0	3.0	3.0	3.0	3.0	3.0
T2	3.3	3.3	4.1	4.3	4.4	4.6	4.8	5.0

1. All dimensions are in millimetres.
2. For sharp corners radius = 0.3R
3. BS:1474 (amended version)
BS EN 755 series for tolerances unless mentioned otherwise.
4. F = full rad; R1 = 0.3 rad; R2 = 0.5 rad; R3 = 4.0 rad.
5. Material - Aluminium Alloy - 6082-T6 / 6063-T6.

Fixing Clip Details

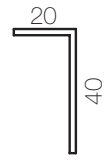

Drip Angle 20x40x2

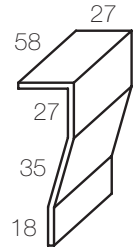

T-Seam® Gable End Clamp

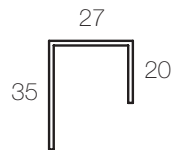

Gable End Clip (Channel)

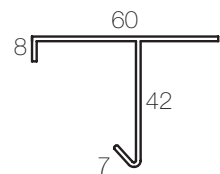

Gable End Support (Clip)



Spacer Profile

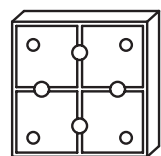

Nylon Thermo Pad T-Seam® Clips

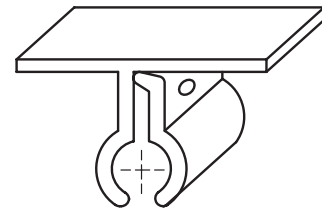

T-Seam® Clamps

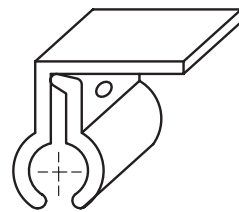

T-Seam® Clamps

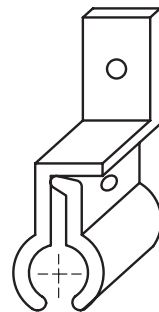

T-Seam® Clamps



T-Seam® Eave Filler Block



T-Seam® Ridge Filler Block

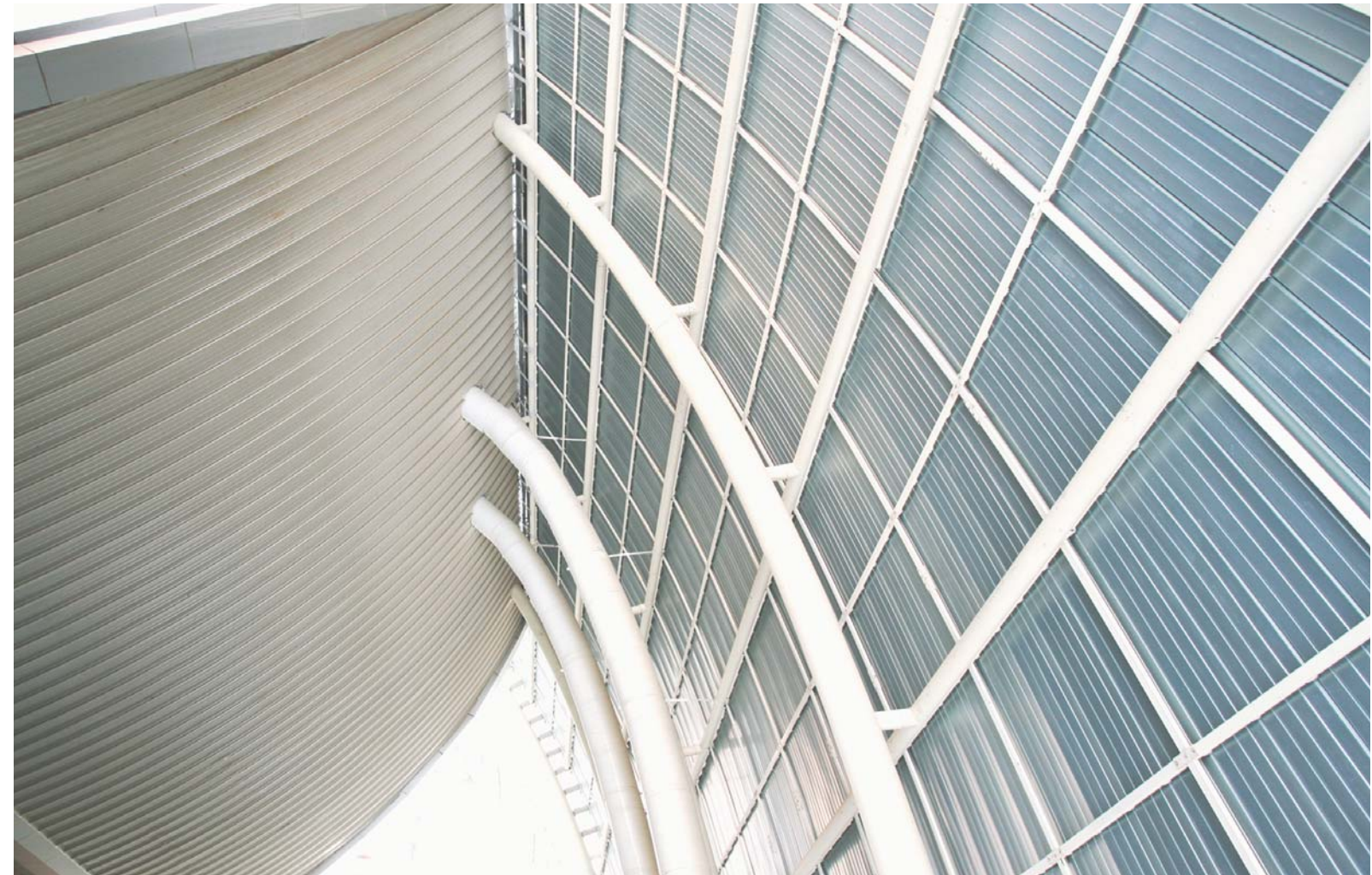

T-Seam roofing at CERT, Abu Dhabi.

T-Seam® Accessories

www.tiger-group.co.ae



Tiger Profiles and Insulation L. L. C.

Tel: +971 6 5338449 Fax: +971 6 5336673
email: info@tigerprofiles.com
P.O. Box 23499, Sharjah, United Arab Emirates